

TECHNISCHE INFORMATIONEN

Balgen :	0.5 Faltenbalg
Federweg :	4mm
Form :	Flach
Höhe :	19.5
Horizontalkraft :	14 N
Kategorie :	Flach
Lippendurchmesser :	21.5
Material :	Polyurethan
Rohrinnendurchmesser :	M5
Serie :	99
Sortiment :	Sauggreifer
Vertikalkraft :	7 N

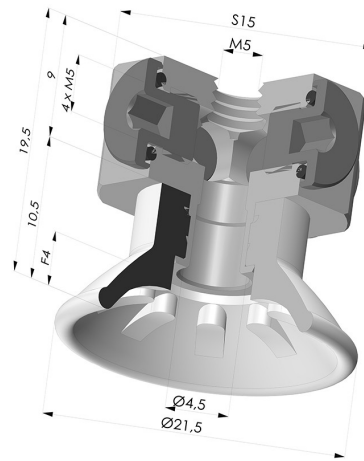

Varianten:



Variantenreferenz:

99A 20PU FM5BD

- Farbe: Rot
- Materiale: Polyurethan
- Shore-Härte: SH40



Variantenreferenz:

99B 20PU FM5BD

- Farbe: Grün
- Materiale: Polyurethan
- Shore-Härte: SH60

Ähnliche Produkte:

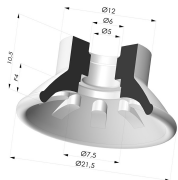

Flachsauggreifer Serie 99 Ø 21.5 mm

Produktreferenz: 99- 20PU A